

SMARTPRO[®]

Generation Ahead Technology

Gem-Eye I

USER MANUAL BOOK

www.smartproinstrument.com



SMARTPRO[®]
GENERATION AHEAD TECHNOLOGY

CONTENTS

I. Introduction	04
II. About the SmartPro Gem-Eye I	05
III. IMPORTANT NOTICE	10
1. GETTING STARTED	12
2. PERFORMING A TEST	26
3. READING TEST RESULTS	29
4. TAKING CARE	32

I. Introduction

Congratulations on your new SmartPro Gem-Eye I with a remarkable designed Gemstone Tester with color stone estimator display for smoothly and seamlessly testing your precious stone and diamond.

In creating SmartPro Gem-Eye I, professional engineers selected every material and element to have this fine-looking and effective tester that helps in the distinguishing between diamond and its other simulants using the principles of thermal conductivity. This device provides fairly consistent and reliable test results.

II. About the SmartPro Gem-Eye I

The SmartPro Gem-Eye I it was developed remarkable design; color estimator to distinguish between diamond and its other simulants using the principles of thermal conductivity.

It is to be noted that natural and synthetic gemstones have similar physical and optical properties. As such SmartPro Gem-Eye I does not distinguish between natural and synthetic gemstones.

As with all thermal testers in the market, the tester is not able to differentiate between natural diamonds and moissanite.

The SmartPro Gem-Eye I has been subjected to through factory quality control and will generally give a clear and reliable reading of the gemstone being tested under proper use. However, you are advised to conduct further supporting tests.

The SmartPro Gem-Eye I features the following:

- a. High efficiency gem tester.
- b. Retractable thermoelectric probe tip that ensures constant pressure between probe tip and gemstone.
- c. Industry's thinnest probe tip (0.48mm) for testing diamonds as small as 0.01ct.
- d. LEDs indicator.
- e. Metal alert LEDs with buzzer sound to ensure that probe tip is in contact with gemstone during testing.
- f. Easy-to-read analog panel display.
- g. No waiting time between tests.
- h. Automatic power off within 2 minutes (Sleep mode).
- i. Built-in diamond and simulant test discs for reference.
- j. Powered by AAA batteries x 3 or adapter.

Included in your package:

- a. SmartPro Gem-Eye I
- b. Probe pen
- c. AC adapter
- d. User manual book
- e. Warranty card
- f. Protective carry case
- g. Probe tip oxidation sheet
- h. Metal stone tray

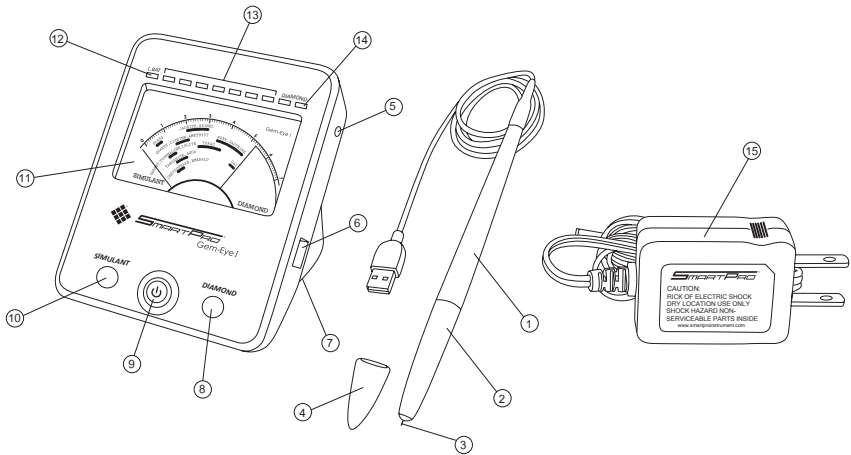

Composition

1. Probe pen
2. Metal handle
3. Retractable probe tip
4. Probe protective cap
5. Adaptor inlet
6. Probe pen socket
7. Battery compartment
8. Diamond test disc
9. ON/OFF switch
10. Simulant test disc
11. Analog panel display
12. Low battery indicator red LED
13. Simulant indicator green LEDs
14. Diamond Indicator blue LEDs

15. AC Adaptor

III. IMPORTANT NOTICE

- a. Keep the tester dry. Precipitation and all types of liquids or moisture can contain minerals that will corrode electronic circuits. If your tester does get wet, remove the batteries, and allow the tester to dry completely before replacing it.
- b. Do not use, store or expose the tester in dusty and dirty areas. It's moving part and electronic components can be damage.
- c. Do not use, store or expose the tester in hot areas. High temperatures can damage or shorten the life of the tester, damage batteries, and warp or melt certain plastics.
- d. Do not use, store or expose the tester in cold areas. When the tester returns to its normal temperature, moisture can form inside the device and damage electronic circuit boards.
- e. Do not attempt to open the tester other than as instructed in this user manual book.

- f. Do not drop, knock, or shake the tester. Rough handling can break internal circuit boards and fine mechanics.
- g. Do not use harsh chemicals, cleaning solvents, or strong detergents to clean the tester.
- h. Do not paint the tester. Paint can clog the moving parts and prevent proper operation.

If the tester is not working properly, kindly contact our customer service at customercare@smartproinstrument.com

SmartPro Instrument co.,ltd.
249/40, Moo 9, J.S.P. Building
Bangbon 1 Rd., Bangbon
Bangkok 10150 Thailand
+66 (0) 2 899 2956-7
Attn: Customer Service Executive

1. GETTING STARTED

Powering up

This tester can be powered by either the use of batteries or through the use of an AC adaptor.

Batteries are required AAA x 3 batteries, take note of the positive (+) and negative (-) directions of batteries (**Fig 1.1**). The use of alkaline batteries is preferred, as it should generally give approximately 2 and half hours of continuous operation.

AC adaptor is used, connect one end to the tester Adaptor inlet and the other end directly into an electrical outlet (**Fig 1.2**). Please ensure that only the adaptor supplied by SmartPro is used.

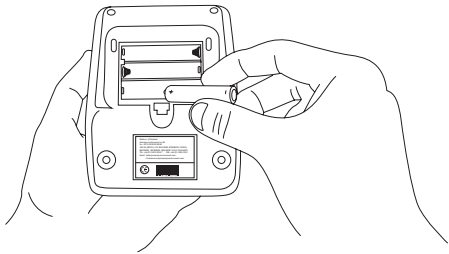

Fig. 1.1

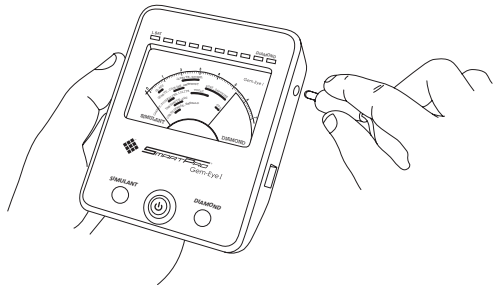

Fig. 1.2

Turning on

Insert the probe pen into the socket at side of the tester (**Fig 1.3**). Note that the probe pen must be inserted into the socket before turning on the tester.

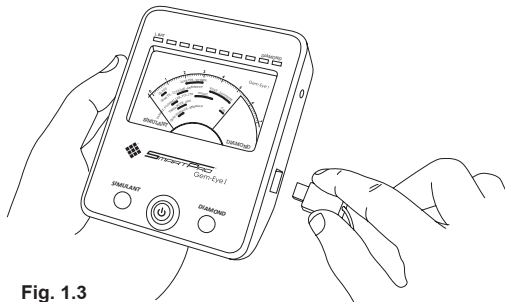

Fig. 1.3

When pushing the button switch there will be the initial warm-up period. It will show the status by the lighting of the LEDs. The button switch will light green color then the GREEN LEDs above the panel will light and running continuously until reach the 2 of BLUE LEDs will blinking with sound 2 times. At this point, the needle position slightly at zero scale. So, It's means your tester is ready now for use (**Fig 1.4**).

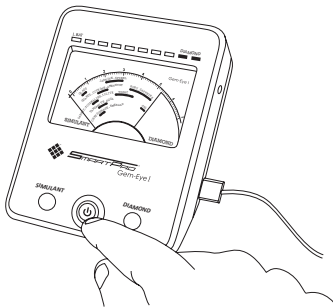

Fig. 1.4

Testing to ensure your SmartPro Gem-Eye I is functioning properly

Simulant test disc

Press the probe tip onto the simulant test disc (**Fig.1.5**). Apply sufficient pressure to retract the protruding tip completely into the probe pen. The indicator should rise to and remain within the center of red strip with “CAL” printed on top within 3 seconds.

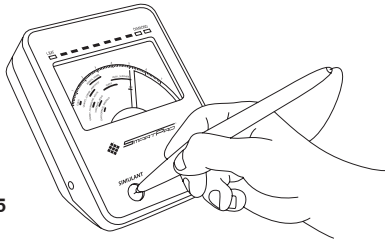

Fig. 1.5

Diamond test disc

Press the probe tip onto the diamond test disc (**Fig.1.6**). Apply sufficient pressure to retract the protruding tip completely into the probe pen. Once this has been completed, the needle should rise and reach its highest point well within the blue band of the panel display, also the 7 GREEN LEDs will light stable then all the BLUE LED 2 times blinking with sound.

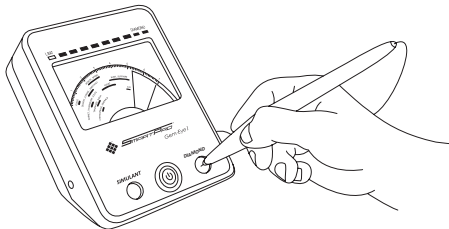

Fig. 1.6

Cleaning the probe tip

Please note that if the tester is being used for the first time, or if the tester has not been used for a week, it is advisable to clean the probe tip using an oxidation removal sheet to attain consistent and accurate reading. Rub the tip gently across the paper surface before testing.

- a. Ensure the unit is switched off.
- b. Hold the probe pen with pen tip forming the right angle (90 degree) with any paper or stone tray (as provide). Gently move in a circular motion without retracting the tip. **(Fig. 1.7)**
- c. Repeat the same motion several times. The cleaning process is completed and tester is now ready for use.

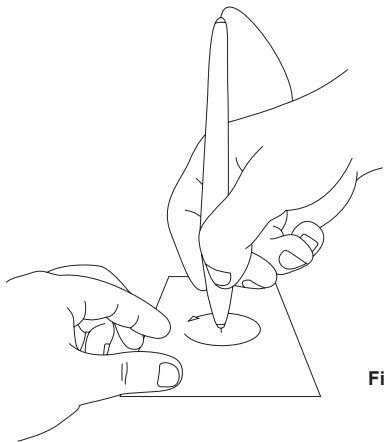

Fig. 1.7

Recommended testing conditions

The gemstone should be clean and dry before testing. However, elaborate cleaning procedures are not normally necessary (**Fig.1.8**). The recommended testing temperature is 18°C - 27°C or 65°F - 80°F Please allow the gemstone or jewelry piece to adjust to room temperature prior to testing. Exposure and/or operation of the tester outside the room temperature would affect the result and performance of tester.

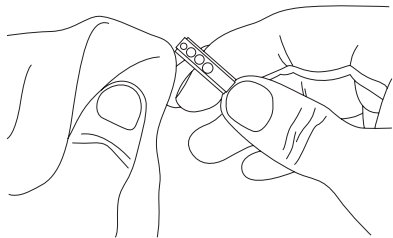

Fig. 1.8

The probe tip must be placed at the right angle or perpendicular to the facet of gemstone for an accurate reading.

Tests should be conducted on the table of the gemstone. In the event of any doubt, kindly test on the girdle of the gemstones instead.

To achieve optimum accuracy for tests involving very small gemstones, it is important to allow the gemstone to cool down before subsequent tests.

It is advisable to take multiple readings regarding the test results indicated.

Cleaning your gemstone prior to testing

Prepare a clean tissue. Carefully retrieve the gemstone with tweezers and place the gemstone face down on the table (**Fig.1.9**).

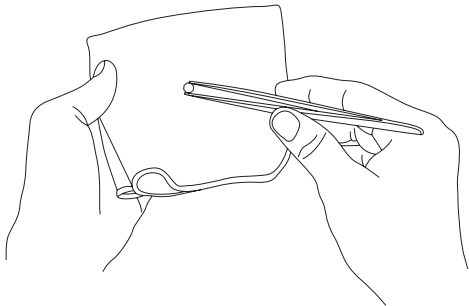

Fig. 1.9

Gently rub the table of gemstone against the tissue/jewelry cloth and place the gemstone on the center of the test pad (**Fig.1.10**).

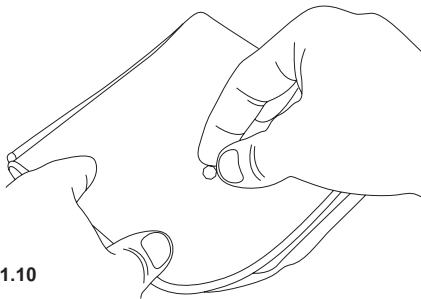

Fig. 1.10

Battery information

Do not leave worn out batteries in the battery compartment as the batteries may corrode, leak, and damage the tester. Batteries should be removed when the tester is expected to be stored for an extended period of time.

To prevent inaccurate readings, replace with new batteries when low power of battery the RED LED will continuously light blinking with buzzer sound.

Calibration

All testers have been calibrated during the manufacturing process and no further adjustment or user intervention to the tester is required.

Self-calibration should not be attempted. To minimize any risk associated, user should contact SmartPro at customercare@smartproinstrument.com or its service center for assistance. In the event that users require the manufacturer to re-calibrate the unit, the users will bear the associated to/from freight cost for the shipping of unit to the service center.

2. PERFORMING A TEST

Place the tip of the probe pen against the gemstone. Apply minimal pressure to fully depress the tip into the probe pen for correct reading. This is to provide a steady and constant contact made between the probe tip and the gemstone.

For mounted jewelry or gemstones:

Hold the jewelry or gemstone with one hand while holding the probe pen with the other hand (**Fig.2.1**). Care should be taken when testing mounted jewelry. User must ensure that the stones are securely mounted before conducting a test as gap between stone and setting might lead to inaccurate reading.

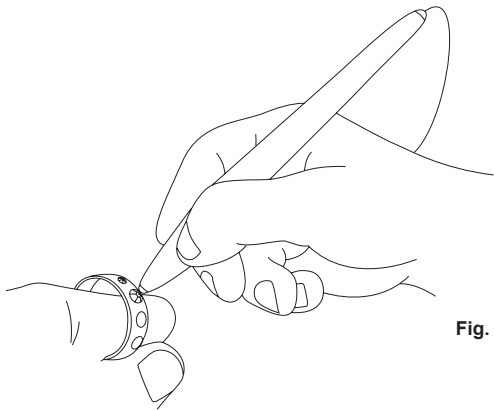

Fig. 2.1

For testing loose gemstones:

Place the gemstone on the metal stone tray and hold it with one hand while holding the probe pen with the other hand (**Fig.2.2**).

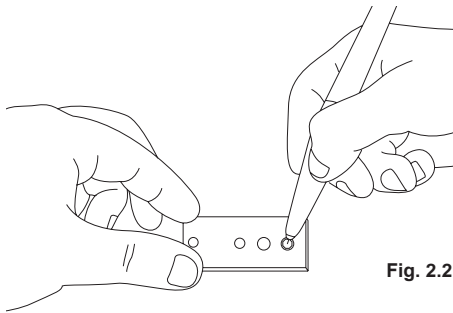

Fig. 2.2

3. READING TEST RESULTS

The test results are indicated as follows:

- a. After pressing the probe tip on the stone for about 2 seconds, the indicator needle will reach its highest position, then slowly fall back. Take the reading at the highest position.
- b. The tester will provide all possible results on the display.
- c. The SmartPro Gem-Eye I should be used only to confirm the identity of suspected gemstone.
- d. An example of reading the result on the meter is given **(Fig. 2.3)**.

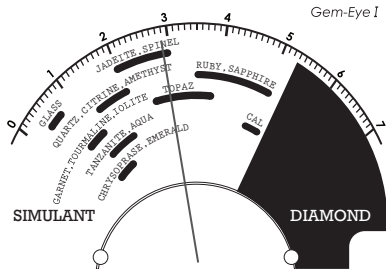

Fig. 2.3

When the indicator stops at the above position, the stone tested may be Jadeite, Spinel or Topaz, i.e., any stones that fall within the ORANGE strip that the indicator passes.

- WHITE band: Simulant is detected if the needle falls into this band.
- BLUE band: Diamond is detected if the needle falls into this band.

Relatively low readings in the blue zone must be expected with very small diamonds. Based on the thermal test result, SmartPro Gem-Eye I can easily distinguish between:

Sapphire	vs.	Tanzanite	Jadeite	vs.	Chrysoprase
Sapphire	vs.	Iolite	Jadeite	vs.	Aventurine Quartz
Sapphire	vs.	Spinel	Ruby	vs.	Spinel
Sapphire	vs.	Citrine	Ruby	vs.	Garnet
Sapphire	vs.	Topaz	Topaz	vs.	Aquamarine
Sapphire	vs.	Tourmaline	Topaz	vs.	Amethyst
Emerald	vs.	Jadeite	Topaz	vs.	Citrine
Emerald	vs.	Garnet	Spinel	vs.	Garnet
Jadeite	vs.	Garnet	Gemstones	vs.	Glass

The use of the thermal results is restricted to the gemstones listed above and will assist the jeweler to distinguish the many confusing gemstones in the market.

4. TAKING CARE

- a. The probe and wire tip is extremely sensitive and should be handled with care. Caution should be taken so as not to damage the probe tip.
- b. If sensor damage, broken or the probe pen not connected to the Gem-Eye I unit, the GREEN LED will Light running continuously. So It's means the device not ready to be used.
- c. Do not leave worn out batteries in the battery compartment as the batteries may corrode, leak or damage the tester. Batteries should be removed when the tester is expected to be stored for an extended period of time.

Your tester is a product of extensive design and craftsmanship and should be treated with care. Thank you for choosing our SmartPro Gem-Eye I and taking time for the user manual book which will enable you to understand your recent purchase better.

SmartPro Instrument also recommends that you register your warranty by sending the warranty registration card to us or registering online at <http://www.smartproinstrument.com>

SmartPro Instrument Co., Ltd.
www.smartproinstrument.com

Copyright © 2014 SmartPro Instrument Co., Ltd.
All rights reserved.